

ANTENNAS | XPOL-2-5G SERIES

X-POLARISED, UNI-DIRECTIONAL LTE ANTENNA

698 – 3800 MHz, 11 dBi; 2X2 MIMO

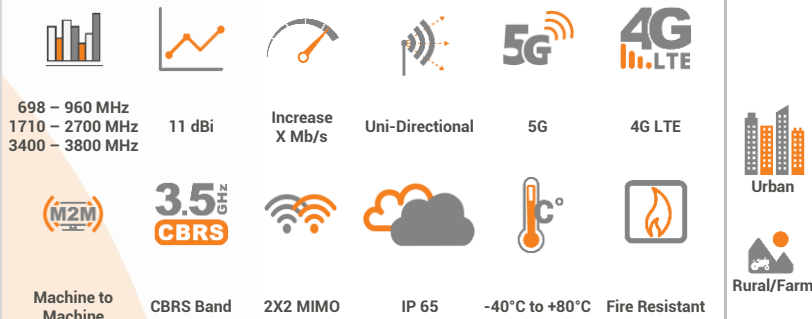

- New advanced metamaterial technology
- Exceptional high gain performance over the main 4G/5G bands
- Wideband 2X2 MIMO 4G/5G antenna
- Backwards compatible 2G/3G/4G/LTE antenna (5G Ready)
- Two cross polarised antennas in one enclosure for optimal LTE performance
- IP65 weather/dust and vandal resistant enclosure.

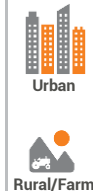

APPLICATION AREAS

Product Overview

The XPOL-2-5G is Poynting's third generation "V3" of this very popular Cross Polarised (XPOL), cellular band, 2x2 MIMO antenna. The antenna enclosure effectively looks the same as the second generation "V2" but has been completely redesigned on the inside. We have used advanced metamaterial technology, making use of Artificial Magnetic Conductors (AMC) and new registered/patent pending radiator configuration, which is proving to yield exceptional improvements in bandwidth and gain. Radiation patterns of this antenna are exceptionally well controlled, further adding to the performance of the antenna.

The XPOL-2-5G antenna includes the newer 3400 - 3800 MHz bands, which were not previously covered by our V2 and is suitable for 2G, 3G, 4G & 5G. This antenna performs exceptionally well in the following frequency bands: 698 – 960 MHz, 1700 – 2170 MHz, 2300 – 2700 MHz & 3400 – 3800 MHz. In addition to the new bands, the gain in the 1700 MHz and 2.7 GHz is around 3 dB higher than the "V2" over the same frequency bands! Our "V2" antenna already outperformed most competitors over these bands, so this substantial improvement in gain shows the benefits of the new advanced materials and novel radiator design.

So, if it was a car, we installed an entirely new technology engine producing twice the power under the bonnet – it may look the same, but just wait until you turn the ignition on!

Features

- 2-3 dBi higher gain over all the bands compared to "V2"
- New 3400 to 3800MHz, 5G band with 11dBi gain
- Consistent broadband performance
- X-Polarised 2X2 MIMO Antenna
- Wall or pole mountable
- Lightweight & Rugged
- Weatherproof & waterproof (IP65)
- High pattern consistency across bands for 4G/5G carrier aggregation

Application Areas

- Outdoor antenna for Fixed Wireless Access (FWA)
- Consumer LTE/5G internet connectivity
- Industrial & Commercial LTE/5G deployments
- Urban and rural household reception enhancement
- Agricultural & Farming LTE/5G data distribution
- Power, Energy & Water telemetry access
- Oil & Gas communication systems
- Municipal & Government systems
- Repeaters & coverage enhancement amplifiers



Frequency Bands

The XPOL-2-5G is a directional antenna that works from 698 – 960 MHz | 1710 – 2700 MHz | 3400 – 3800 MHz | and the following Wi-Fi frequency bands | 2400 – 2500 MHz |

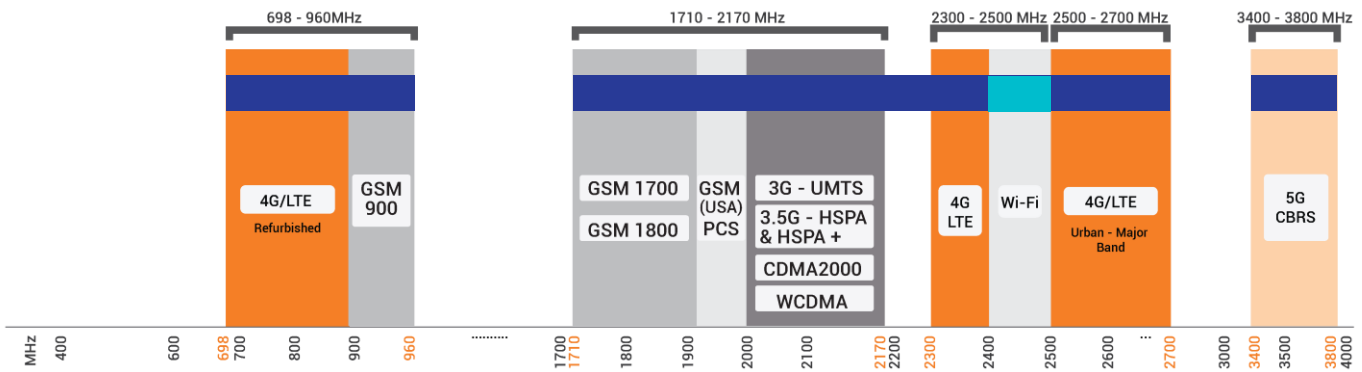

Indicates the LTE bands on which XPOL-2-5G works

Indicates the WI-FI bands on which XPOL-2-5G works

Antenna Derivatives

Product Order Code (SKU)	A-XPOL-0002-V3-01	A-XPOL-0002-V3-02	A-XPOL-0002-V3-03
Coax Cable Type	Twin HDF 195	N/A	Twin HDF 195
Coax Cable Length	5m	N/A	10m
Connector Type	SMA (M)	N-Type (F)	SMA (M)
Product Weight	1.55 kg	1.43 kg	1.73 kg
Packaged Weight	1.98 kg	1.86 kg	2.16 kg
EAN	6009880915750	6009710920107	6009710920121

**The coax cable & connector are factory mounted to the antenna*

Electrical Specifications

Frequency Bands:	698 – 960 MHz 1710 -2700 MHz 3400 – 3800 MHz
Gain (Max):	9 dBi @ 698 – 960 MHz 10 dBi @ 1710 -2700 MHz 11 dBi @ 3400 – 3800 MHz
VSWR:	<1.5:1 Over 95% of the band
Feed Power Handling:	10 W
Input Impedance:	50 Ohm (nominal)
Polarisation:	±45°
Coax Cable Loss:	0.362 dB/m @ 900 MHz 0.514 dB/m @ 1800 MHz 0.533 dB/m @ 2400 MHz 0.603 dB/m @ 3000 MHz
DC Short:	Path to ground

Product Box Contents

Antenna:	A-XPOL-0002-V3
Mounting Bracket:	Z-shaped mounting bracket

Mechanical Specifications

Product Dimensions	265 mm x 265 mm x 90 mm
Packaged Dimensions:	375 mm x 270 mm x 100 mm
Radome Material:	UV Stable ASA
Radome Colour:	Brilliant White Pantone P 179-1 C
Mounting Type:	Wall and Pole mount

Environmental Specifications, Certification & Approvals

Wind Survival:	Antenna wind survival: ≤ 250 km/h Included Z-Bracket wind survival: ≤160km/h Optional bracket BRKT-030* is required for wind speeds of ≤250 km/h
Temperature Range (Operating):	-40°C to +80°C
Environmental Conditions:	Outdoor/Indoor
Water ingress protection ratio/standard:	IP 65
Salt Spray:	MIL-STD 810G/ASTM B117
Operating Relative Humidity:	Up to 98%
Storage Humidity:	5% to 95% - non-condensing
Storage Temperature:	-40°C to +80°C
Enclosure Flammability Rating:	UL 94-HB
Impact resistance:	IK 08
Product Safety & Environmental:	Complies with CE and RoHS standards

BRKT-030 is an optional accessory, which is required for high wind areas of up to 250km/h. The BRKT-030 requires 4 x M6 x 20mm bolts for installation, not included



Antenna Performance Plots

VSWR

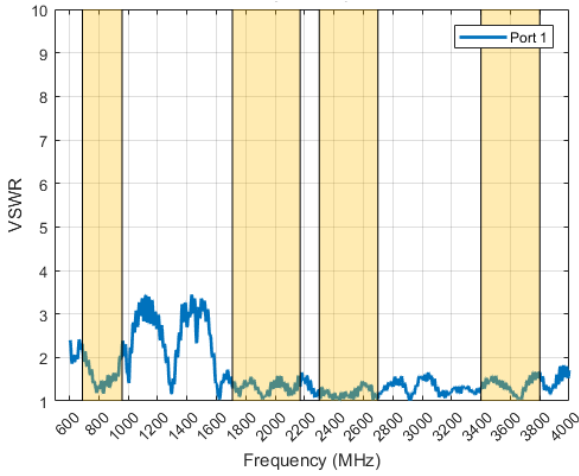

Voltage Standing Wave Ratio (VSWR)*

VSWR is a measure of how efficiently radio-frequency power is transmitted from a power source, through a transmission line, into a load. In an ideal system, 100% of the energy is transmitted which corresponds to a VSWR of 1:1.

The XPOL-2-5G delivers superior performance across all bands with a VSWR of $\leq 1.5:1$ over 95% of the band.

*VSWR measured with a 5m low loss cable.

GAIN (EXCLUDING CABLE LOSS)

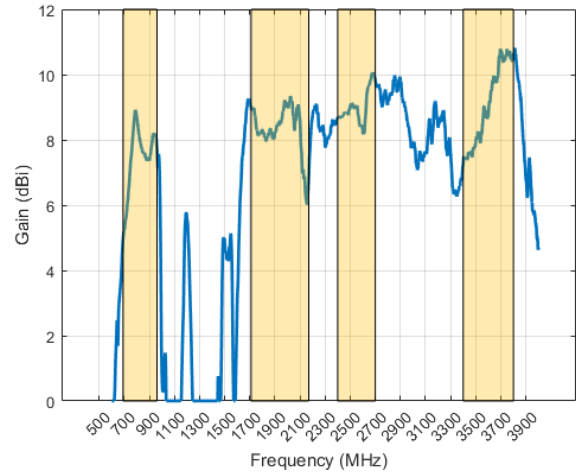

Gain* in dBi

11 dBi is the peak gain across all bands from 698 – 3800 MHz

Gain @ 698 – 960 MHz:	9 dBi
Gain @ 1710 – 2700 MHz:	10 dBi
Gain @ 3400 – 3800 MHz:	11 dBi

*Antenna gain measured with polarisation aligned standard antenna

Technical Drawings

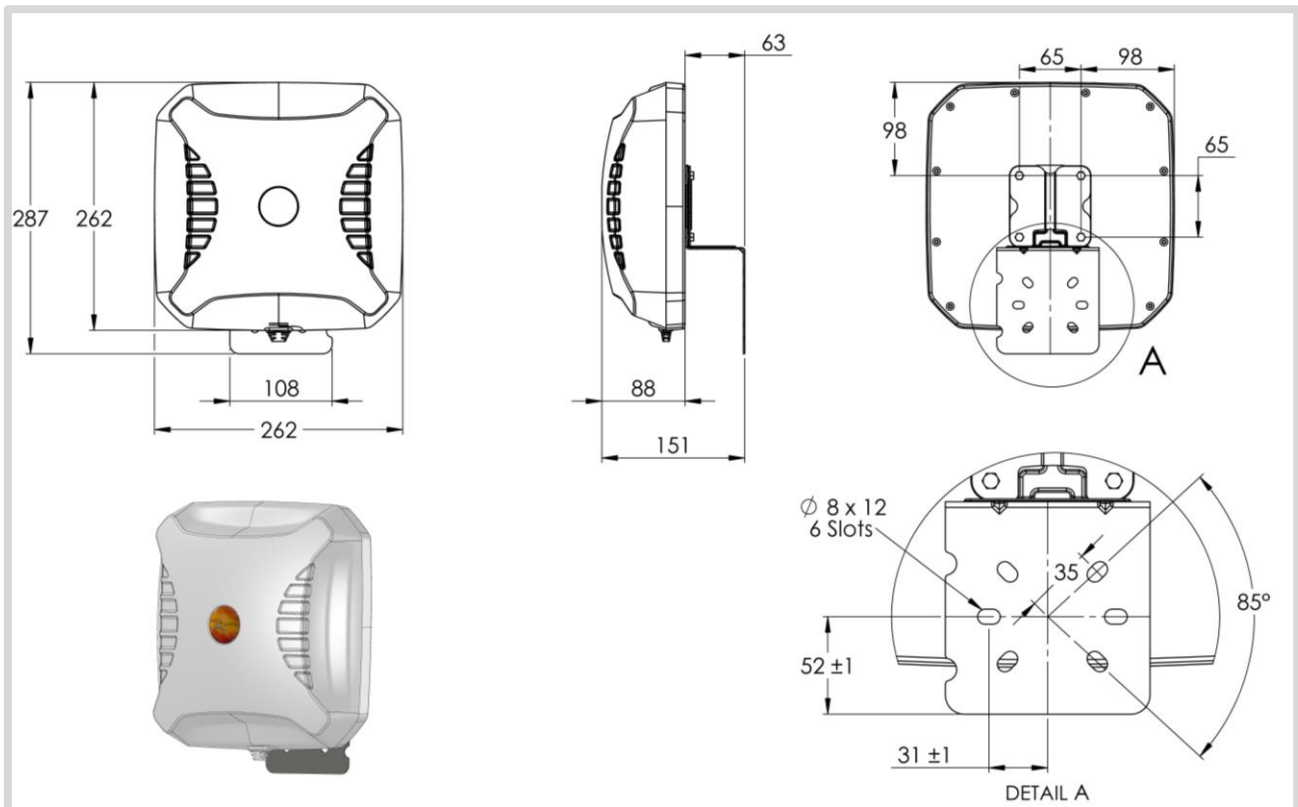

Radiation Patterns

Azimuth (Top View): 698 – 960 MHz

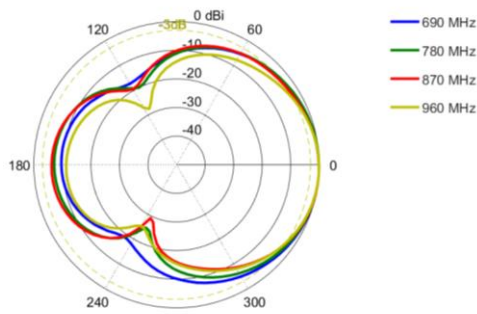

Azimuth (Top View): 1710 – 2170 MHz

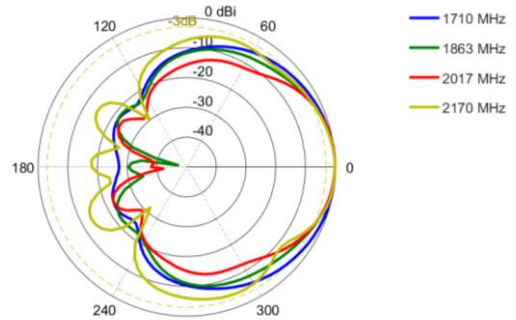

Azimuth (Top View): 2300 – 2700 MHz

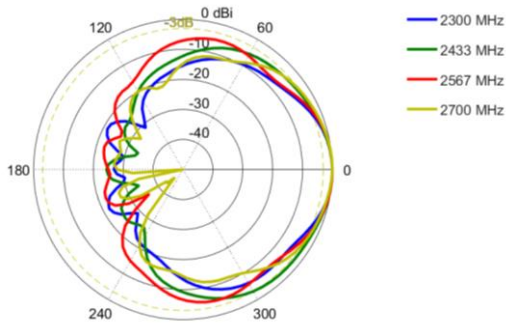

Azimuth (Top View): 3400 – 3800 MHz

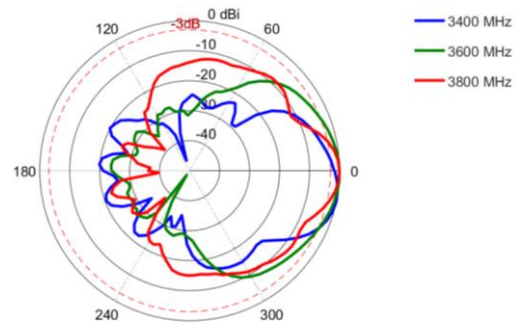

Elevation (Side View): 698 – 960 MHz

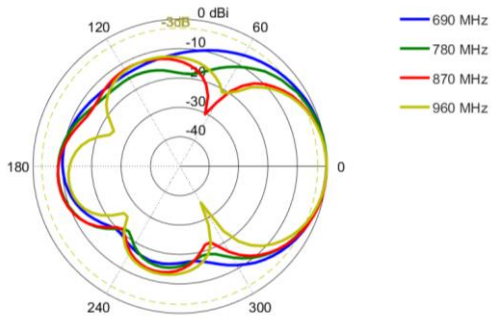

Elevation (Side View): 1710 – 2170 MHz

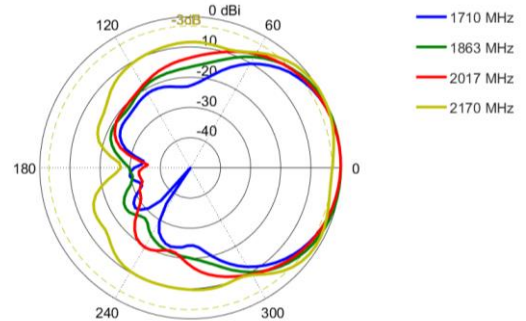

Elevation (Side View): 2300 – 2700 MHz

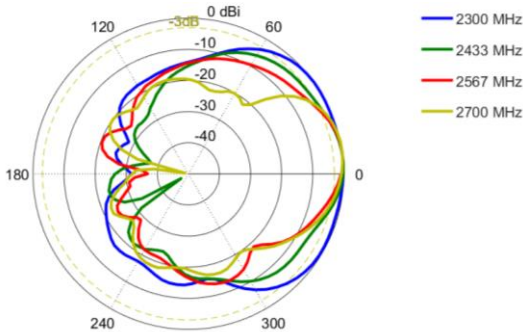

Elevation (Side View): 3400 – 3800 MHz

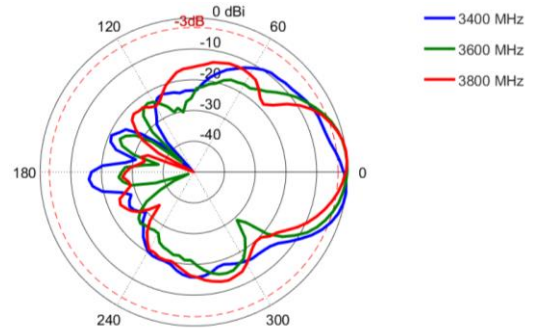

Mounting Options

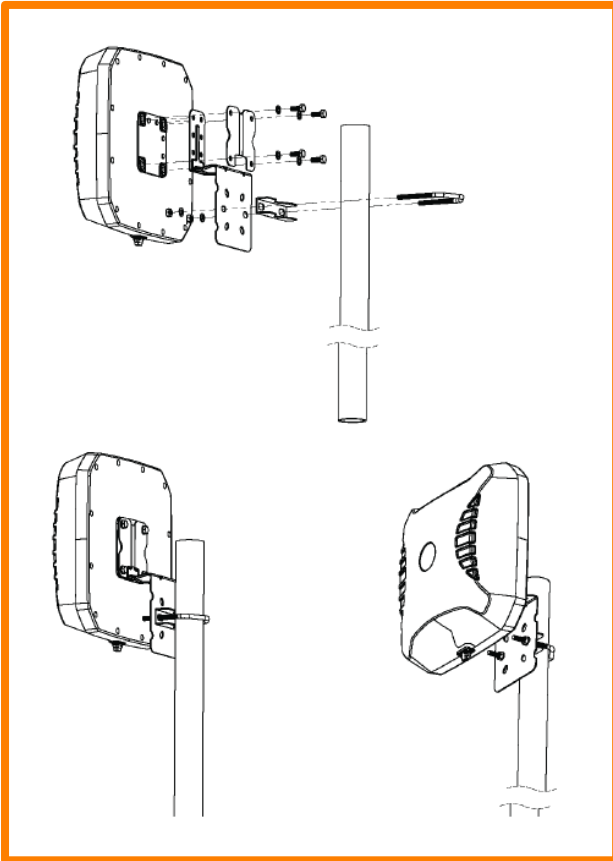

Pole Mount

Pole/Wall mounting bracket (included)

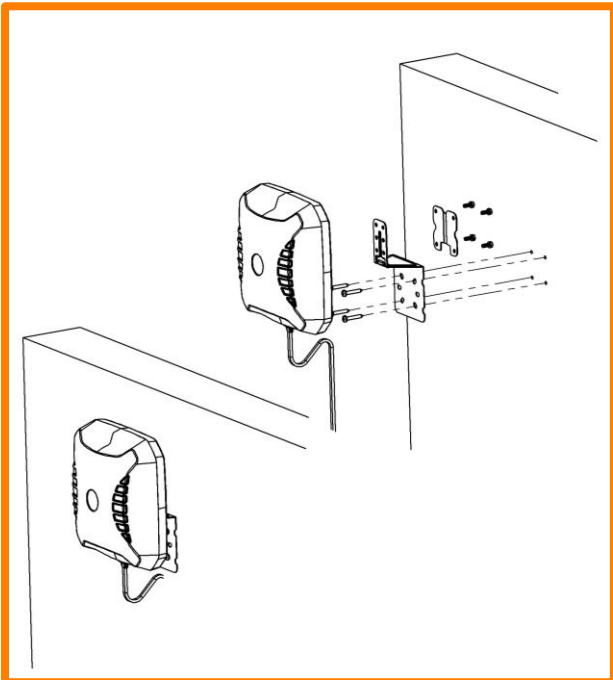

Wall Mount

Pole/Wall mounting bracket (included)

Additional Accessories

Extension Cables: Up to 10m HDF 195
Various connectors available
Installation poles and brackets available

See accessories technical specifications on www.poynting.tech

CONTACT POYNTING

Poynting Antennas (Pty) Ltd - Head Office

Unit 4, N1 Industrial Park,
Landmarks Avenue,
Samrand, 0157, South Africa

Phone: +27 (0) 12 657 0050

E-mail: info@poynting.tech

International Email: sales-global@poynting.tech

Poynting Europe

Regus Business Center Neue Messe Riem
Kronstadter Straße 4
81677 München
Germany

Phone: +49 89 7453 9002

E-mail: sales-europe@poynting.tech

Poynting USA

1804 Owen Court, Suite 104,
Mansfield,
TX 76063
USA

Phone: +1 817 533-8130

E-mail: sales-us@poynting.tech